

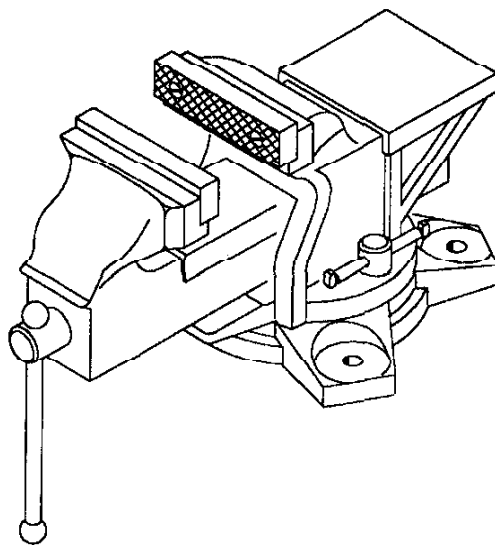

Heavy Duty Vise Model 3794



ASSEMBLY AND OPERATING INSTRUCTIONS



3491 Mission Oaks Blvd./Camarillo, CA 93011

Copyright © 1997 by Harbor Freight Tools. All rights reserved.
No portion of this manual or any artwork contained herein may be reproduced in any
shape or form without the express written consent of Harbor Freight Tools.

For technical questions and replacement parts, please call 1-800-444-3353.

Invoice No. _____ Purchase Date: _____



SPECIFICATIONS

Type Double Anvil
Base 120 Degree Swivel
Width 7-3/4 Inches
Depth 13 Inches
Height 6-3/4 Inches
Jaw Opening 4-3/4 Inches
Body and Sides High Grade Cast Iron
Screws and Jaws High Quality Carbon Steel
Jaws Replaceable, Hardened
Weight 30 Pounds

SAVE THIS MANUAL

This manual covers safety instructions, operation, assembly procedures, and parts list for Heavy Duty Vise, Model 3794. Please keep this manual and invoice accessible for future reference.

**READ ENTIRE MANUAL BEFORE
ASSEMBLING OR OPERATING THE
HEAVY DUTY VISE.**



WARNINGS AND SAFETY PRECAUTIONS

WARNING

When using this vise in conjunction with electrical equipment, follow basic safety precautions to prevent electrical shock, fire hazards, and personal injury.

Read all the instructions in this section before proceeding.

1. Keep work area clean, dry and well lit.
2. Do not use this equipment within reach of children.
3. Store equipment not in immediate use in a dry, locked area.
4. Use the proper size vise for the work to be performed.
5. Dress appropriately and sensibly. Gloves and non-skid footwear are recommended to be worn in a workshop environment. Jewelry, loose clothing, long hair can be dangerous hazards as they can be caught in most machinery.
6. Wear eye, nose and ear protection when appropriate. A full mask should be worn when metal filings, chips or dust are produced. A dust mask should be used when dust is produced. When loud or high pitch noise is produced, use approved ear protection. Goggles and ear protections are available from Harbor Freight Tools.
7. Use clamps in conjunction with the vise to secure work operation. Proper clamping will free your hands to operate equipment.
8. Keep your balance at all times. Do not lift equipment beyond your capability. Keep floor dry and free from debris.
9. Stay alert. Do not operate equipment when tired. Observe normal work procedures and use common sense during work operations.
10. Equipment should be properly maintained and lubricated to provide recommended performance. Keep handles and security devices tight and free from damage.
11. Check equipment at regular intervals for damage, corrosion, and wear. If any parts appear damaged, replace the part or assembly. Check parts for proper operation, alignment, and adjustment.
12. When replacing parts, use identical replacement parts. Use recommended accessories with this equipment. Approved accessories are available from Harbor Freight Tools.
13. Do not operate equipment when under the influence of alcohol or drugs. Observe warning labels and instructions on prescriptions. When capability is uncertain, do not operate equipment.

UNPACKING

Open carton and remove vise from packing material.

Check parts and assemblies for damaged or missing items. Refer to the parts diagram for location and identification of parts.

If any parts or assemblies are found defective, contact Harbor Freight Tools for warranty replacement.

Clean your heavy duty vise to remove preservation solution. Use a degreasing solvent or soap and water to remove preservative covering.

DESCRIPTION

The Heavy Duty Vise provides many uses on your workbench. Features include a lockable swivel base allowing accurate alignment to clamped material. The vise has a serrated jaw plate which provides a secure surface for holding work material without causing damage from slipping. The vise also provides an anvil behind the vise jaws. The anvil's machined surface is approximately 3-1/5 x 3-1/5 inches, providing an area for layout and hammering. Two base locking levers (T-nuts) are provided to secure the body of the vise to its base. A spring is located on the handle screw inside the vise which allows easy opening and closing of the vise jaws. Enjoy the countless uses which your Heavy Duty Vise enables you to perform while holding work material securely in position.

ASSEMBLY

The Heavy Duty Vise has three mounting holes on the base (see Figure 1) for mounting to a workbench. Heavy duty hardware must be used to secure the vise to the workbench. Make sure that the vise mounting bolts are tight and that the vise is secure before use.

Mounting to a Wood Workbench

- Step 1: Measure the thickness of the workbench. It is suggested that to securely mount your vise to a wooden workbench, mount 2"W x 2"H x 8"L lengths of wood underneath the mounting points for the vise to add strength.
- Step 2. Purchase three bolts, nuts, and flat washers the appropriate length for the workbench plus 1" of length for the vise.
- Step 3. Mark and drill holes through the workbench, using the base as a template, for the three mounting tabs on the base of the vise.

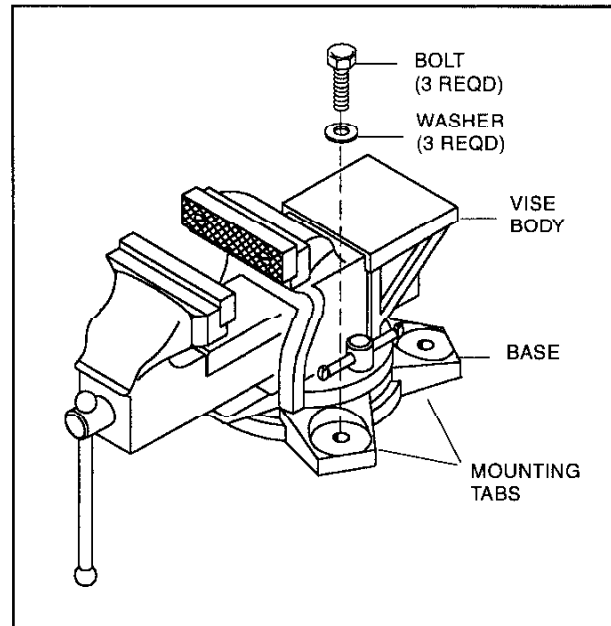

Figure 1. Mounting Vise to a Workbench

- Step 4. Position the vise on the workbench and line up the holes drilled in Step 3 with the holes in the mounting tabs.
- Step 5. Insert bolts into the mounting tabs and through the workbench as shown in Figure 1.
- Step 6. Tighten bolts securely.

Mounting to a Metal Workbench

- Step 1. Measure the thickness of the workbench. It is suggested that an 8" square by 3/16" thick reinforcing plate be cut and ready to mount beneath the workbench when Step 7 is performed.
- Step 2. Purchase three bolts, nuts, and flat washers the appropriate length for the workbench plus 1" of length for the vise.
- Step 3. Mark and drill holes through the workbench, using the base as a template, for



the three mounting tabs on the base of the vise.

- Step 4. Mark and drill the reinforcing plate, using the base of the vise as a template.
- Step 5. Position the vise on the workbench and line up the holes drilled in Step 3 with the holes in the mounting tabs.
- Step 6. Mount the vise to the workbench as shown in Figure 1.
- Step 7. Remember to attach the reinforcing plate underneath the workbench, then thread on the nuts and tighten the bolts.

Your Heavy Duty Vise comes pre-assembled with pipe jaw plates. If you need a machined clamping surface for your material, refer to the steps below:

- Step 1. Open the vise fully open by turning the handle counterclockwise as shown in Step 2.
- Step 2. With a large standard screwdriver, remove the two screws that attach the

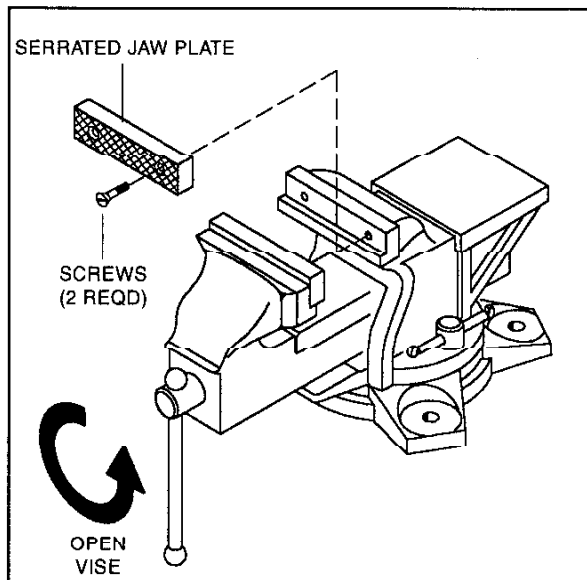

Figure 2. Pipe Jaw Plate Removal

pipe jaw plates to the vice as shown in Figure 2.

- Step 3. Repeat Step 2 on the remaining pipe jaw plate.
- Step 4. Place the four screws and two jaw plates in a container and label it.

Your vise is now ready for use with machined clamping surfaces.

OPERATION

Clamping

- Step 1. Select either the pipe jaw plates or machined surface for use, according to the material you are working on, as described in ASSEMBLY.
- Step 2. Open vise by turning the handle counterclockwise, until you have 1/4" of space between your material and each jaw of the vise.
- Step 3. Hold material between the jaws while you slowly tighten the vise by turning the handle clockwise.
- Step 4. When your material is snug between the jaws, stop tightening.
- Step 5. Tighten the vise until you can no longer move the material you are working. Do Not Over Tighten.

CAUTION

Do Not Over Tighten. You can damage or crush your material. If crushing begins, STOP!

- Step 6. When finished working on the material, turn the handle counterclockwise. This will release the material from the vise.

Swivel Base

When the material is securely clamped in the vise, decide if you need to rotate the vise to allow better and safer access to material while working. If you need to change the position of the vise, refer to steps below.

Step 1. Locate the base locking levers (T-nuts), one to each side of the vise, as shown in Figure 3.

Step 2. Unlock each base locking lever by turning it counterclockwise as shown in Figure 3.

Step 3. Swivel the vise until you have better and safer access to your material.

Step 4. Lock each base locking lever by turning it clockwise until tight.

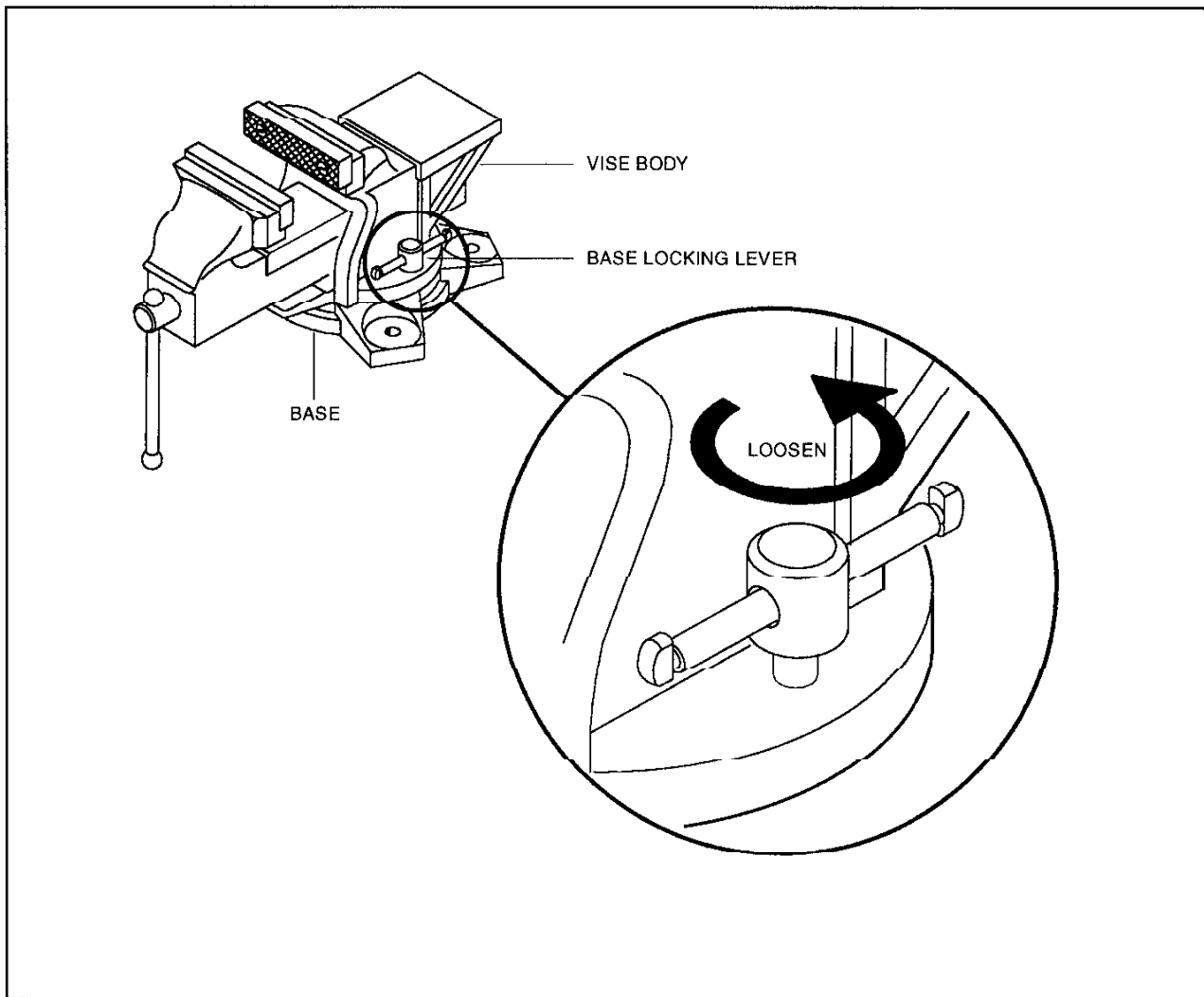

Figure 3. Loosen Base Locking Lever

PARTS LIST

Figure 4 is the exploded view parts diagram of the Heavy Duty Vise.

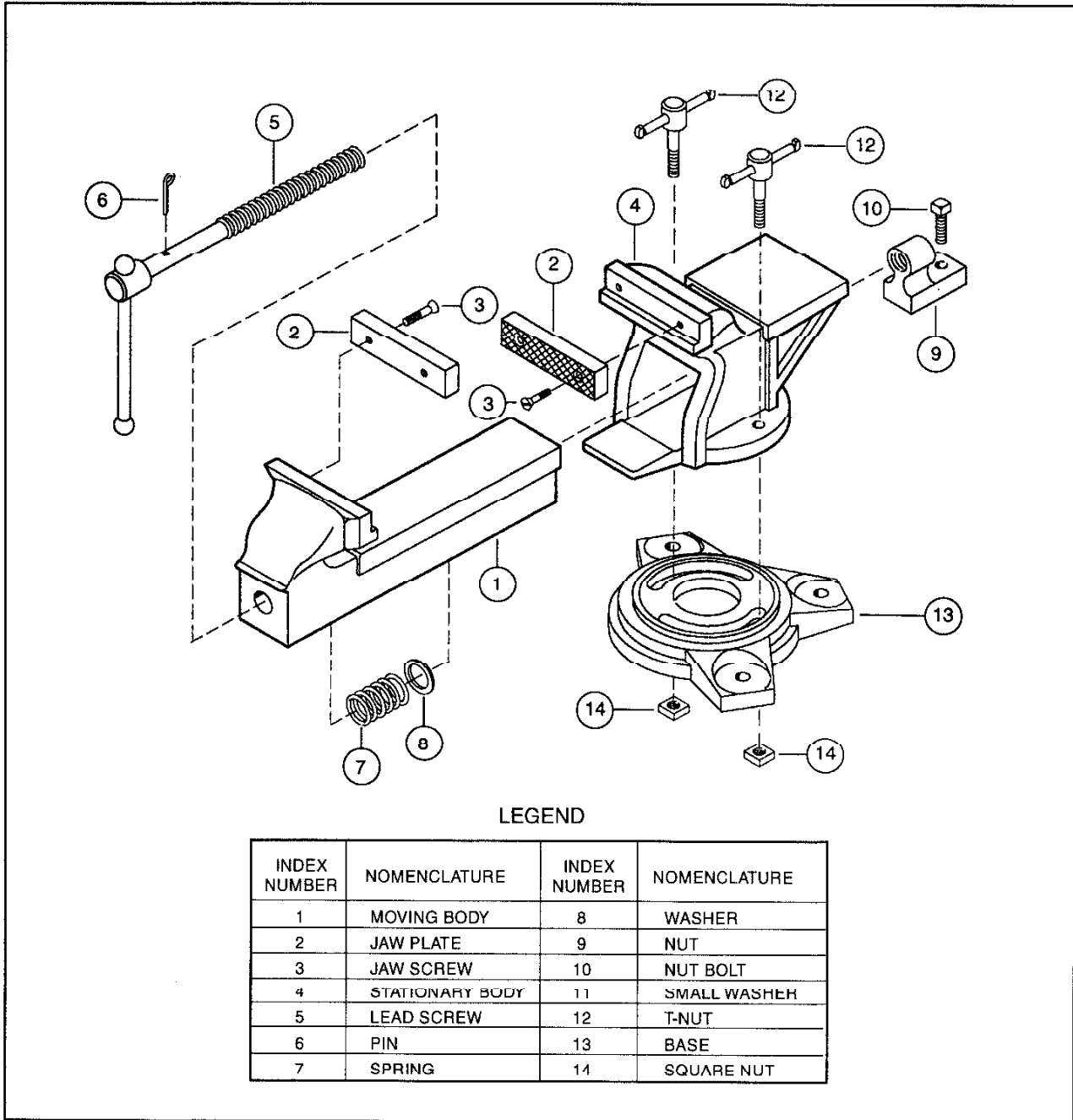

Figure 4. Heavy Duty Vise Parts Diagram